



Technical Catalog

SAB-HW Series Hot Water Driven Absorption Chiller

15 to 1000 Nominal Tons (52 to 3516 kW)



CHP Solution Inc. USA

SAB-HW, Hot water driven absorption chillers, provides a heat recovery water chilling to CHP system and heat recovery facilities.

- No CFC's ; environmentally safe
- Quiet, vibration-free operation
- High reliability due to few moving parts

Table of contents

	Page
Model number nomenclature.....	2
Features/Benefits	2-4
Single-effect absorption cycle.....	5
Specification data.....	6-8
Dimensions & Foundation.....	9-16
Product specification.....	17-19
Piping & Instruments.....	20
Controls.....	21
Start-up sequence.....	22-23
Control panel & Electrical data.....	24-25
Hot water control valve & Insulation.....	26
Typical piping & Wiring.....	27

Model number nomenclature

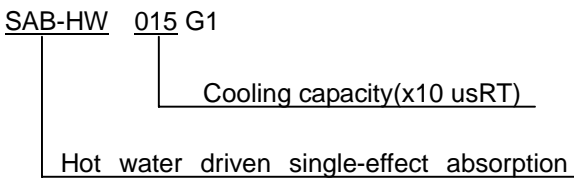

SAB-HW Hot water driven absorption chiller provides economical water chilling for CHP (Cooling, Heating and Power) system.

Heat recovery cooling and excellent part load performance

Exhaust-energy water chilling – SAB-HW Hot water driven absorption chiller produces cooling from exhaust or solar energy. Also, the use of hot water driven

absorption chiller eliminates demand charges and high cost electrical usage.

Application versatility designed to suit a variety of applications - From comfort cooling to providing chilled water for process applications, the SAB-HW absorption chiller offers versatility for almost any job where hot water is available as the heat source, the SAB-HW is sure to be the right choice for either new construction or retrofit applications.

Excellent part load performance - SAB-HW standard concentration control system allows stable, part load operation at cooling water temperatures as low as 63 °F (17 °C) without the need for a cooling water bypass. The SAB-HW has a continuous operating range from 100% to 10% of rated capacity.

Location and installation savings

Ease of installation – SAB-HW absorption chillers are completely fabricated, assembled and wired in the factory as single-piece units.

Single-point box electrical connection - Installation costs are further reduced by eliminating field wiring between machine components. On units shipped as a single assembly, all unit-mounted electrical items are factory-wired to the chiller microprocessor control panel. Only a single-point electrical connection to the chiller from the building's electrical service is required. Voltage transformers, mounted in the chiller control panel, provide secondary, single-phase powers for the SAB-HW control.

Low noise and vibration allows location flexibility - Low sound and vibration levels are characteristic of absorption chillers, primarily due to the fact the only rotating parts are the refrigerant and solution pumps. The overall sound level of SAB-HW is typically 75dbA. This allows the machines to be installed near occupied spaces or in areas with strict sound requirements. Low vibration levels also make it possible to install the chiller on upper floors without special consideration for vibration dampening systems.

Low maintenance cost

Standard features allow simple maintenance procedures - Every SAB-HW absorption chiller has numerous standard design features that provide for convenient and simple maintenance. All moving parts are easily accessible for inspection or replacement, as required.

Leak-proof hermetic pumps cut maintenance costs

– SAB-HW solution, solution spray and refrigerant pumps/motors are leak-proof, completely self-contained, and hermetically sealed. The hermetic design eliminates the need for a separate, complicated, and possibly leak-prone seal water system while providing leak tightness and longer machine life. Specially designed bearings absorb both radial and axial thrusts to ensure correct fit at all times. There is no possibility of external contamination since the fluid being pumped lubricates and cools the pump and motor assemblies. In addition, both the rotor and the stator are separated by a stainless steel liner that protects the windings from the fluid being pumped. As an additional safety feature, thermal over-load switches are embedded in the stator to protect against high winding temperatures. The pumps are field serviceable. Inspection is recommended after 5 years or 20,000 hours of operation, whichever comes first. Pump isolation valves are included on SAB-HW absorption chiller to make field service easy.

Reliable operation

SAB-HW control system features automatic microprocessor control center continuously monitors machine operation, ensuring precise control

– Each SAB-HW absorption chiller includes a factory mounted and wired microprocessor control panel that is functionally tested prior to shipment. Continuous monitoring and control of machine operation are performed automatically. A touch screen type display on the front of the control panel identifies operational status and fault indication. All control panel components and the assembly will meet local codes including CE and KS where appropriate and include a microprocessor CPU (central processing unit) board, molded case circuit breaker, pump contactors, ambient compensated 3-phase pump overload protection, control power transformers, and all other necessary safeties and controls.

As part of the start-up sequence, the chiller microprocessor control panel initiates a self-diagnostic system check to verify that all sensors are in range. Other standard features include a remote start/stop switch and a key-locked control panel door that protects against unauthorized access.

Superior corrosion protection – Absorption chillers must be protected from the possibility of internal corrosion that is always present when lithium bromide solution is in contact with internal machine surfaces. The SAB-HW absorption chiller incorporates a highly effective corrosion inhibitor to provide an extra margin of protection against internal corrosion. Other inhibitors may require the use of exotic tube materials in certain

heat exchangers since they are less effective and require frequent maintenance and analysis. The superior corrosion protection of SAB-HW's inhibitor allows for the use of standard copper tubes throughout the machine. This results in long machine life and dependable operation.

Gravitational dropping refrigerant and solution distribution system (Evaporator, Absorber)

– The refrigerant and solution distribution system in evaporator and absorber is performed based on gravity and siphon phenomenon. This gravitational dropping distribution system adopts stainless steel tray and allows uniform solution spray and continuous heat transfer. Different from nozzle spray type of distribution system, this system does not need external pumps to spray the solutions with nozzles and prevents nozzles from clogging.

Rugged machine construction – Every SAB-HW absorption chiller offers numerous standard features designed to provide reliable, trouble-free operation. The machine is fabricated to meet stringent manufacturing and design requirements and is **CE-listed** to ensure product safety and machine integrity.

Automatic purge system extends machine life and ensures optimum efficiency and performance

– The purge system of an absorption chiller is critical to ensure efficient operation and long machine life. Even when machines are vacuum tight or properly inhibited, all absorption chillers generate hydrogen and other non-condensable gases in small quantities. Since these gases are present in sufficient volume to interfere with proper machine operation, they must be removed to protect the unit from internal corrosion, lithium bromide solution crystallization, and/or a reduction in chiller capacity. SAB-HW purge system protects the machines from these potential hazards by working continuously during machine operation.

During operation, non-condensable gas tends to accumulate in the absorber section, which operates at the lowest internal pressure. A slip-stream of lithium bromide solution from the solution pump discharge flows through an eductor, creating suction that draws non-condensable gas from the absorber. The non-condensable gas is then entrained by the solution flowing through the eductor. The eductor discharges the solution and non-condensable gas into a separator in a purge chamber, where the non-condensable gas are separated from the solution. The non-condensable gas flows to a storage tank, while the solution returns to the absorber pump.

As non-condensable gas accumulates in the external storage tank, they are isolated from the chiller and cannot reenter the machine (even during shutdown).

These gases must periodically be exhausted (as required) from the storage tank by a simple procedure performed while the machine is running. Evacuation can be performed by a unit-mounted vacuum pump

that is connected to the purge evacuation valve. The unit-mounted vacuum pump can also be used during chiller maintenance or service to remove non-condensable gas directly from the machine.

SAB-HW outline – Control panel side

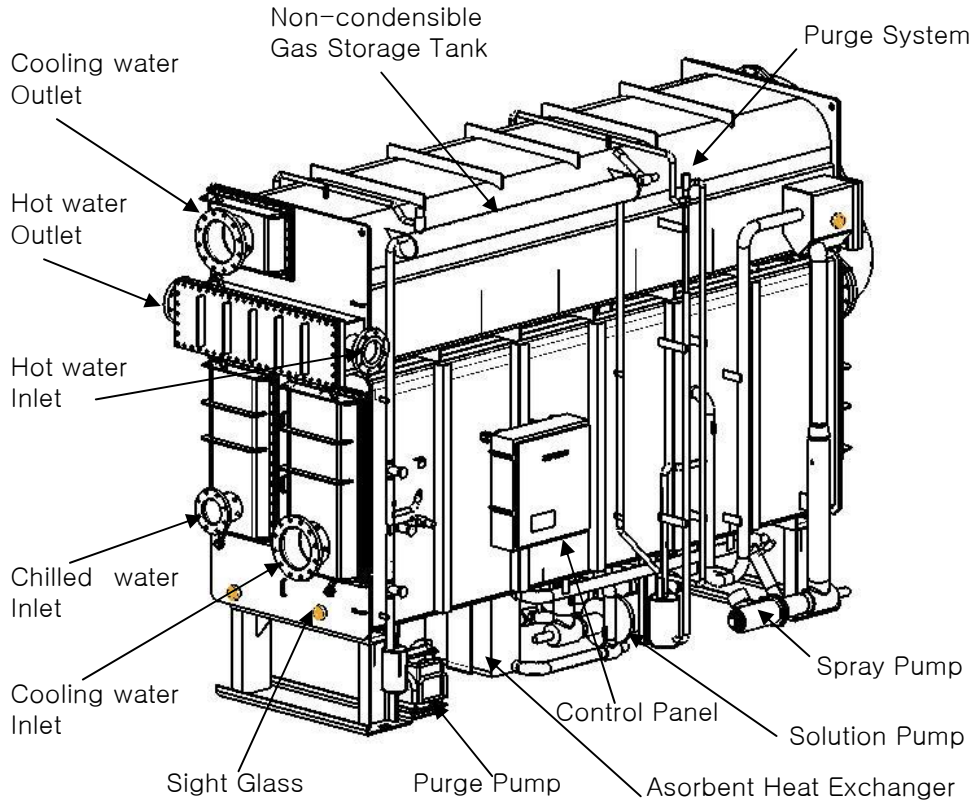

SAB-HW outline – Evaporator side

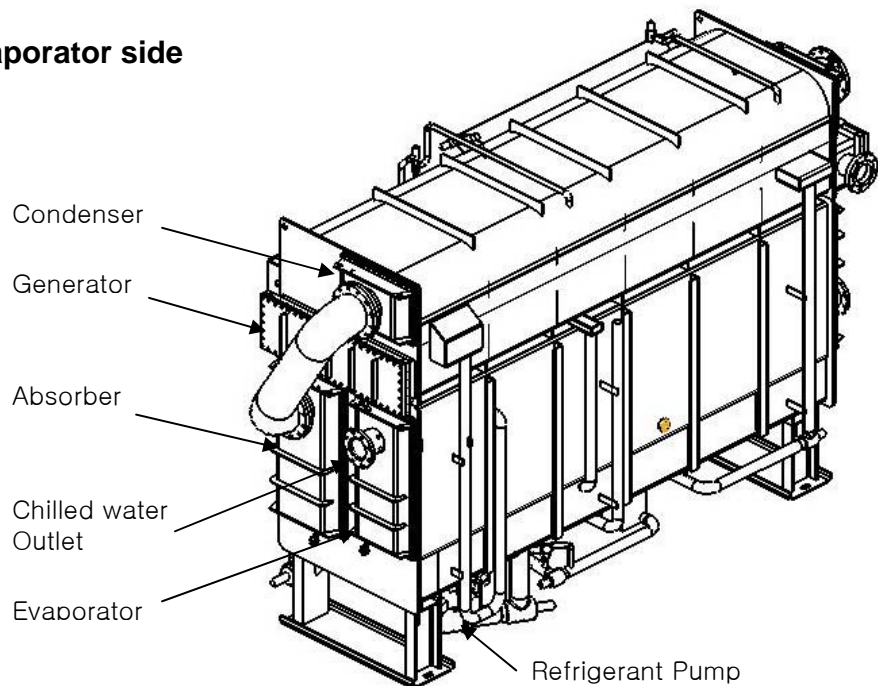

Single-effect absorption cycle

The SAB-HW hot water driven absorption chiller consists of an evaporator, absorber, condenser, generator, solution heat exchanger, refrigerant/ solution pumps, purge and controls. Water is used as the refrigerant in vessels maintained under low absolute pressure (vacuum). The chiller operates on the principle that under vacuum, water boils at a low temperature. In this case water boils at approximately 42°F (5.5°C), thereby cooling the chilled water circulating through the evaporator tubes. A refrigerant pump is used to circulate the refrigerant water over the evaporator tubes to improve heat transfer.

To make the cooling process continuous, the refrigerant vapor must be removed as it is produced. For this, a lithium bromide solution (which has a high affinity for water) is used to absorb the water vapor. As this

process continuous, the lithium bromide becomes diluted, reducing its absorption capacity. A solution pump then transfers, this weak (diluted) solution to the generator where it is concentrated by hot water. The water vapor released in the shell side of the generator, enters the condenser to be cooled and returned to a liquid state. The refrigerant water returns to the evaporator to begin a new cycle.

To remove heat from the machine, relatively cool water from a cooling tower or other source is first circulated through the tubes of the absorber to remove the heat of vaporization. The water is then circulated through the tubes of the condenser. The strong solution from the generator flows back to the absorber to begin a new cycle. For efficiency reasons, the strong solution from the generator is passed through the heat exchanger to preheat the weak solution while pre-cooling the strong solution.

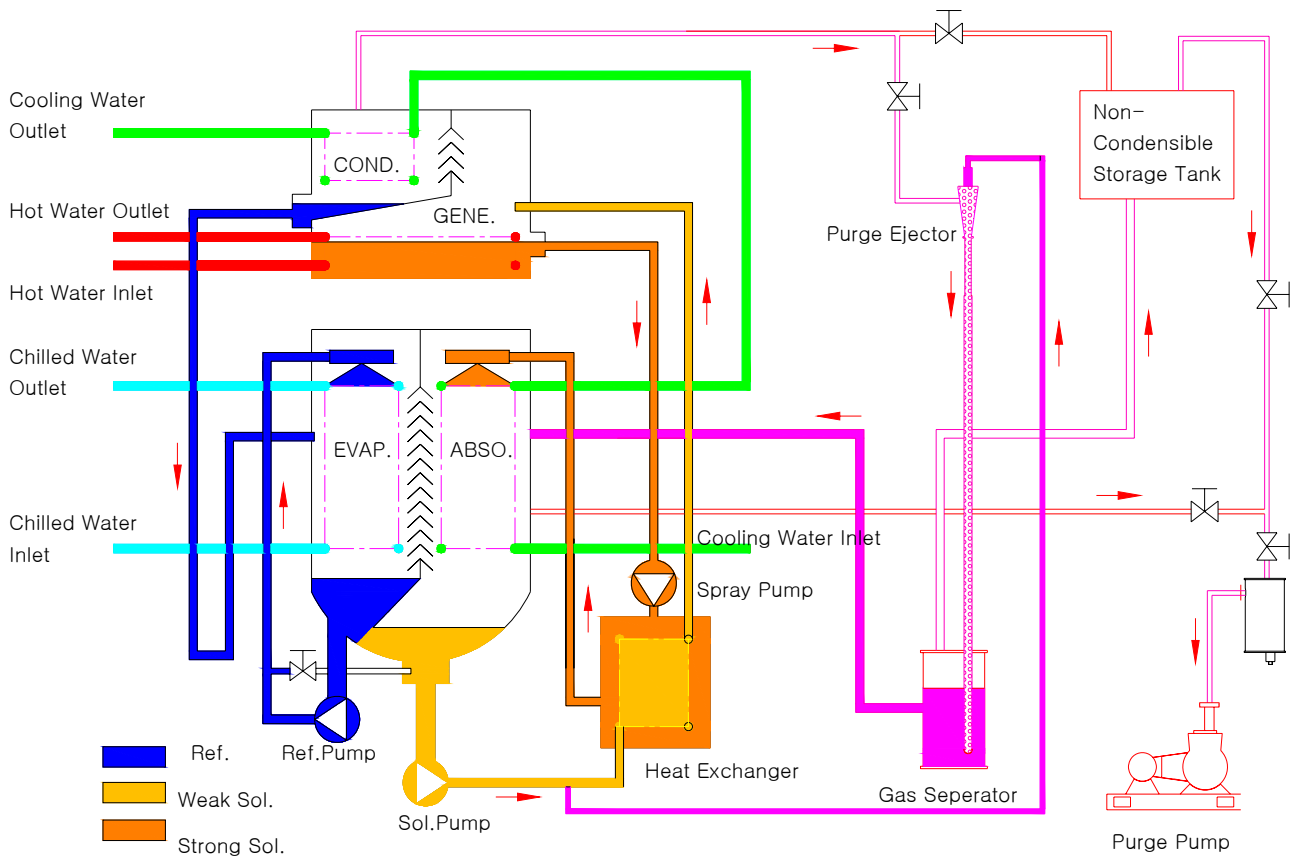

Specification data

Item		Model	SAB-HW							
			001G1	002G1	003G1	004G1	005G1	006G1	008G1	010G1
Cooling Capacity		USRT	15	20	30	40	50	65	80	100
		kW	53	70	105	141	176	229	281	352
		kcal/h	45,360	60,480	90,720	120,960	151,200	196,560	241,920	302,400
Chilled Water	TEMP.	°C	Inlet 13 Outlet 8							
	Flow rate	m ³ /h	9.1	12.1	18.1	24.2	30.2	39.3	48.4	60.5
	PD	kPa	32	50	40	82	84	75	75	67
	Pipe Size	A	40		50	65		80		
	PASS	-	EVEN							
Cooling Water	TEMP.	°C	Inlet 31 Outlet 36.5							
	Flow rate	m ³ /h	19.6	26.1	39.3	52.4	65.5	83.4	102.6	128.3
	PD	kPa	36.5	52	41	85	80	91	91	53
	Pipe Size	A	80			100		125		
	PASS	-	EVEN							
Hot water	TEMP.	°C	Inlet 95 Outlet 80							
	Flow rate	m ³ /h	4.2	5.7	8.4	11.1	13.9	18.1	22.3	27.9
	PD	kPa	18	22	20	21	27	19	19	54
	Pipe Size	A	25		40		50		65	
	PASS	-	EVEN							
Electric Capacity		kVA	3.2		4.1		8.9		9.1	
Motor Output (50Hz)	Sol. P	kW	0.5+0.25		1.1+0.4		2.2+0.75		4.0	
	Ref. P	kW	0.2		0.2		0.4		0.6	
	Vac. P	kW	0.4		0.4		0.4		0.4	
Dimension	Length	mm	1,530		1,952	2,262		2,850	4,005	
	Width	mm	1,690		1,326	1,326		1,427	1,427	
	Height	mm	1,650		2,310	2,310		2,582	2,582	
Tube Space		mm	1,000		1,350	1,650		2,100	3,100	
Operating Weight		Ton	1.8	1.8	2.6	2.8	3.1	3.9	4.0	6.7
Rigging Weight		Ton	1.6	1.6	2.3	2.4	2.8	3.6	3.7	5.5
Insulation Surface	Hot	m ²	4		3.9	4.8		7.5	10	
	Cold	m ²	2.5		4.7	5.8		6.2	8.2	
Cooling Tower model		SCTM	30	50	80	100	125	150	175	225

Notes.

- 1 USRT equals 3,516 kW(3,024 kcal/h)
2. The fouling factor of chilled, cooling and hot water is 0.000086 m² K/W(0.0001 m² h °C/kcal)
3. Maximum permissible pressure for chilled/cooling/hot water is 780 kPa(8 kg/cm² G)

Item		Model	SAB-HW							
			012G1	015G1	018G1	021G1	024G1	028G1	032G1	036G1
Cooling Capacity		USRT	120	150	180	210	240	280	320	360
		kW	422	527	633	738	844	985	1,125	1,265.9
		kcal/h	362,880	453,600	544,320	635,040	725,760	846,720	967,680	1,088,640
Chilled Water	TEMP.	°C	Inlet 13 Outlet 8							
	Flow rate	m ³ /h	72.6	90.7	108.9	127	145.2	169.3	193.5	217.7
	PD	kPa	67	58	57	107	114	101	59	48
	Pipe Size	A	100		125	125			150	
	PASS	-	EVEN						ODD	
Cooling Water	TEMP.	°C	Inlet 31 Outlet 36.5							
	Flow rate	m ³ /h	154	193	231	270	308	360	411	469.1
	PD	kPa	53	56	56	99	99	102	114	93
	Pipe Size	A	125	150	200	200			250	
	PASS	-	EVEN							
Hot water	TEMP.	°C	Inlet 95 Outlet 80							
	Flow rate	m ³ /h	33.4	41.8	50.1	58.5	66.9	78	89.1	100.3
	PD	kPa	54	54	54	35	35	35	49	32
	Pipe Size	A	65	80		100			125	
	PASS	-	EVEN			EVEN				
Electric Capacity		kVA	9.1	9.8			14.4			
Motor Output (50Hz)	Sol. P	kW	2.4+1.6	2.4+2.0			3.7+2.0			
	Ref. P	kW	0.6			2.0				
	Vac. P	kW	0.4							
Dimension	Length	mm	4,005			4,596			5,030	
	Width	mm	1,623			1,704			1,922	
	Height	mm	2,895			3,241			3,240	
Tube Space		mm	3,100			3,650			4,050	
Operating Weight		Ton	6.7	7.2	7.3	10.3	10.4	10.5	11.7	12.6
Rigging Weight		Ton	5.5	6.0	6.1	9.0	9.1	9.2	10.1	10.5
Insulation Surface	Hot	m ²	10			12.5			14.8	
	Cold	m ²	8.2			13.5			15.9	
Cooling Tower model		SCTM	300	350	400	450	600	700	750	800

Notes

- 1 USRT equals 3,516 Kw(3,024 kcal/h)
2. The fouling factor of chilled, cooling and hot water is 0.000086 m² K/W(0.0001 m² h °C/kcal)
3. Maximum permissible pressure for chilled/cooling/hot water is 780 kPa(8 kg/cm² G)

Item		Model	SAB-HW								
			040G1	046G1	052G1	058G1	064G1	072G1	080G1	090G1	100G1
Cooling Capacity		USRT	400	460	520	580	640	720	800	900	1000
		kW	1,407	1,617	1,828	2,039	2,250	2,532	2,813	3,165	3,516
		kcal/h	1,209,600	1,391,040	1,572,480	1,753,920	1,935,360	2,177,280	2,419,200	2,721,600	3,024,000
Chilled Water	TEMP.	°C	Inlet 13 Outlet 8								
	Flow rate	m ³ /h	241.9	278.2	314.5	350.8	387.1	435.5	483.8	544.3	604.8
	PD	kPa	107	110	35	35	59	60	74	98	99
	Pipe Size	A	150	200			250			300	
	PASS	-	ODD			EVEN					
Cooling Water	TEMP.	°C	Inlet 31 Outlet 36.5								
	Flow rate	m ³ /h	514	590	667	744	821	924	1,027	1,155	1,308
	PD	kPa	92	92	98	98	150	152	47	60	60
	Pipe Size	A	250	300			350			400	
	PASS	-	ODD						EVEN		
Hot water	TEMP.	°C	Inlet 95 Outlet 80								
	Flow rate	m ³ /h	111.4	128.1	144.8	161.6	178.3	200.6	222.8	250.7	278.5
	PD	kPa	48	48	35	35	53	53	59	59	58
	Pipe Size	A	125		150			200			
	PASS	-	EVEN								
Electric Capacity		kVA	20.4		20.4		23.5		26.4	29.8	
Motor Output (50Hz)	Sol. P	kW	5.5+3.7				5.5+5.5			7.5+5.5	
	Ref. P	kW	2.0		2.0		2.0		3.7		
	Vac. P	kW	0.4								
Dimension	Length	mm	5,837		6,683		7,433		7,804	8,375	
	Width	mm	1,917		2,039		2,021		2,047	2,158	
	Height	mm	3,201		3,353		3,384		3,358	3,489	
Tube Space		mm	4,850		5,600		6,300		6,600	7,000	
Operating Weight		Ton	14.9	15.1	21.7	22.3	25.4	25.8	27.5	29.2	31.1
Rigging Weight		Ton	13.3	13.5	16.6	16.9	22.1	22.5	23.9	25.4	26.3
Insulation Surface	Hot	m ²	16.6		19.7		21.6		22.7	24.5	
	Cold	m ²	18.2		22		24.6		25.9	27.5	
Cooling Tower model		SCTM	900	1,200	1,200	1,400	1,600	1,600	900*2	1,000*2	1,200*2

Notes.

- 1 USRT equals 3,516 Kw(3,024 kcal/h)
2. The fouling factor of chilled, cooling and hot water is 0.000086 m² K/W(0.0001 m² h °C/kcal)
3. Maximum permissible pressure for chilled/cooling/hot water is 780 kPa(8 kg/cm² G)

Dimensions

HW002G1

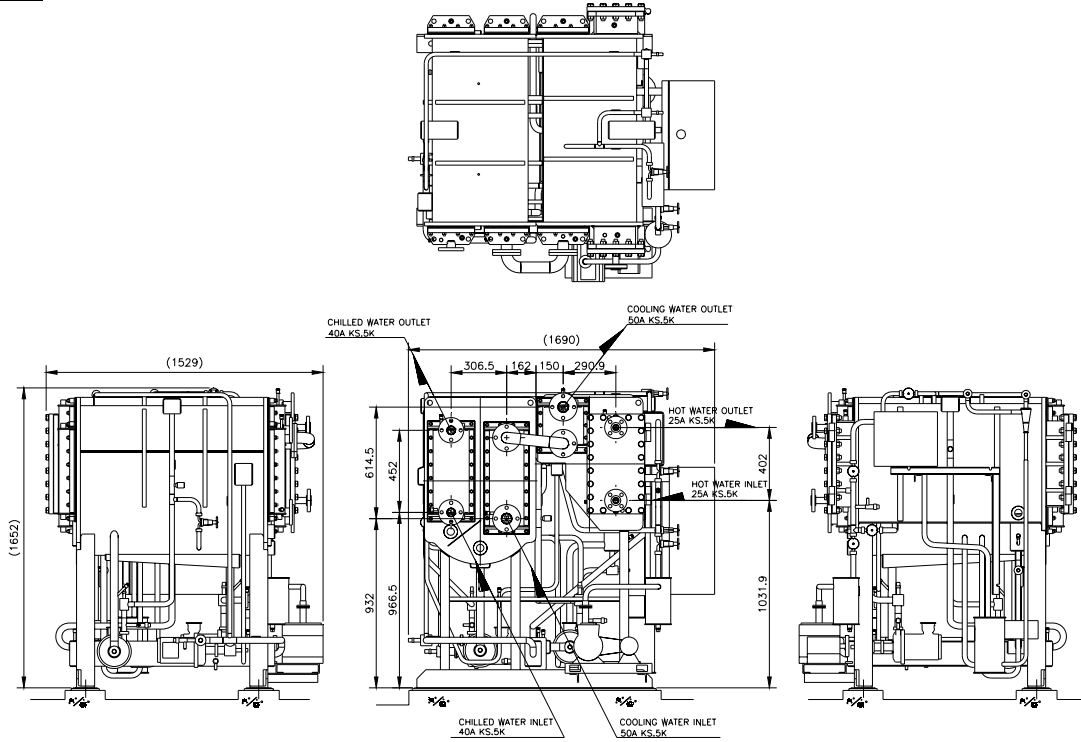

HW003G1

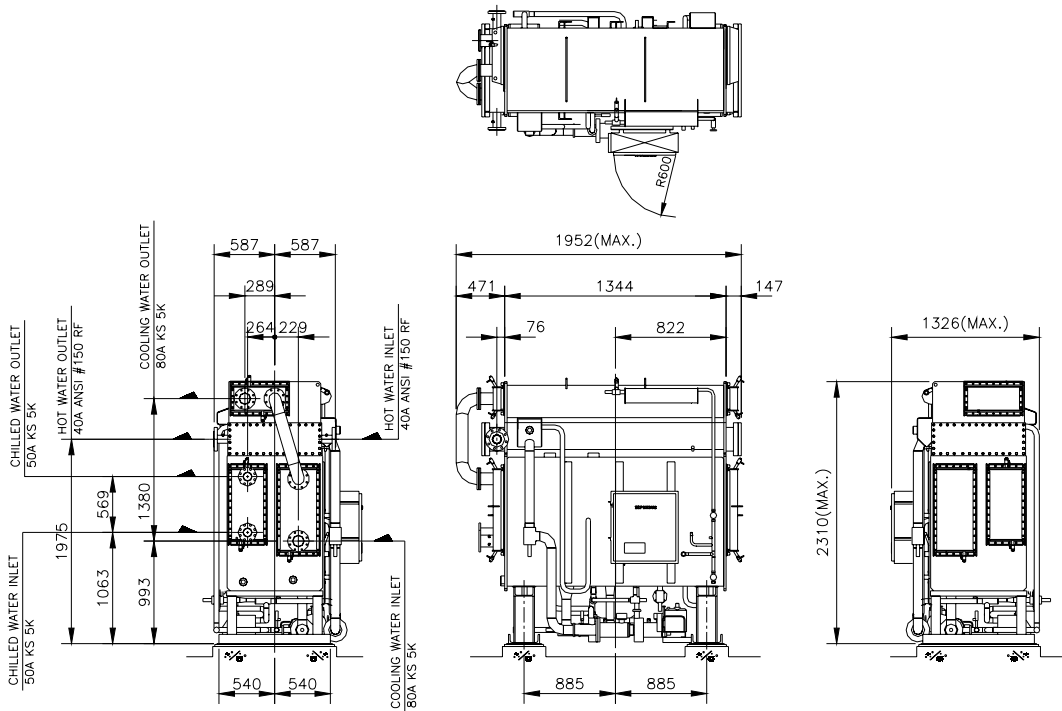

HW004G1 and 005G1

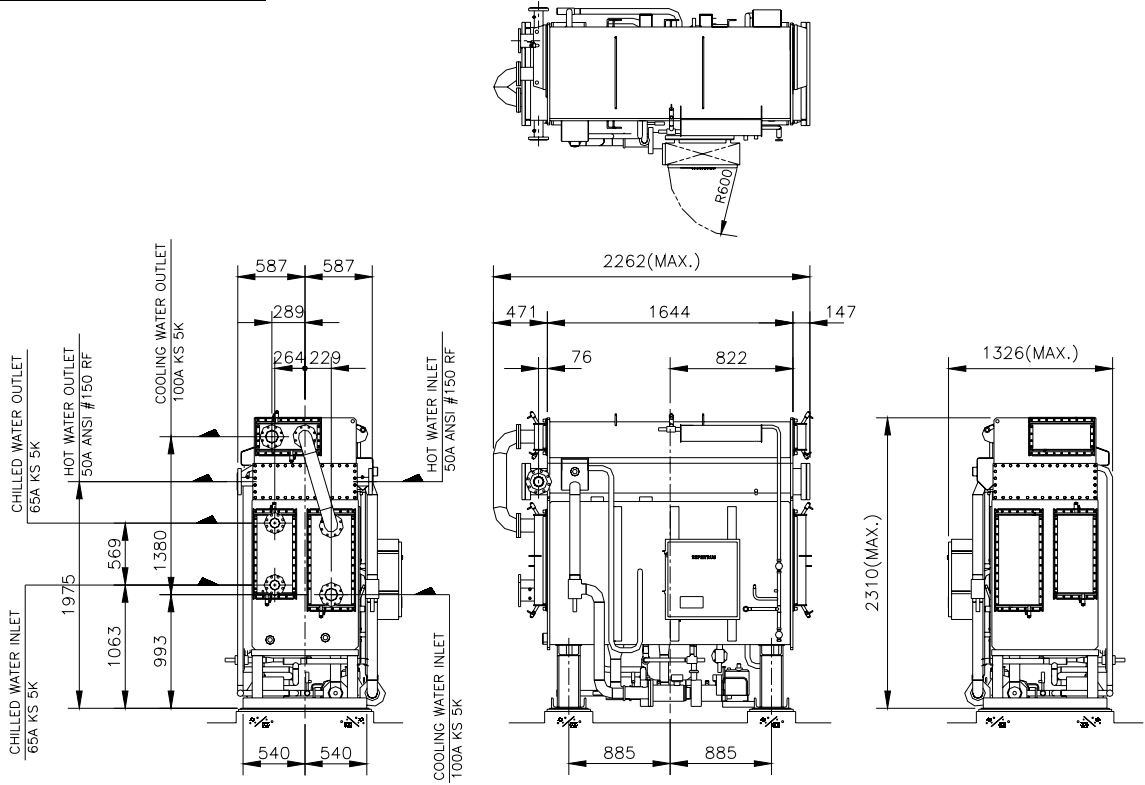

HW006G1 and 008G1

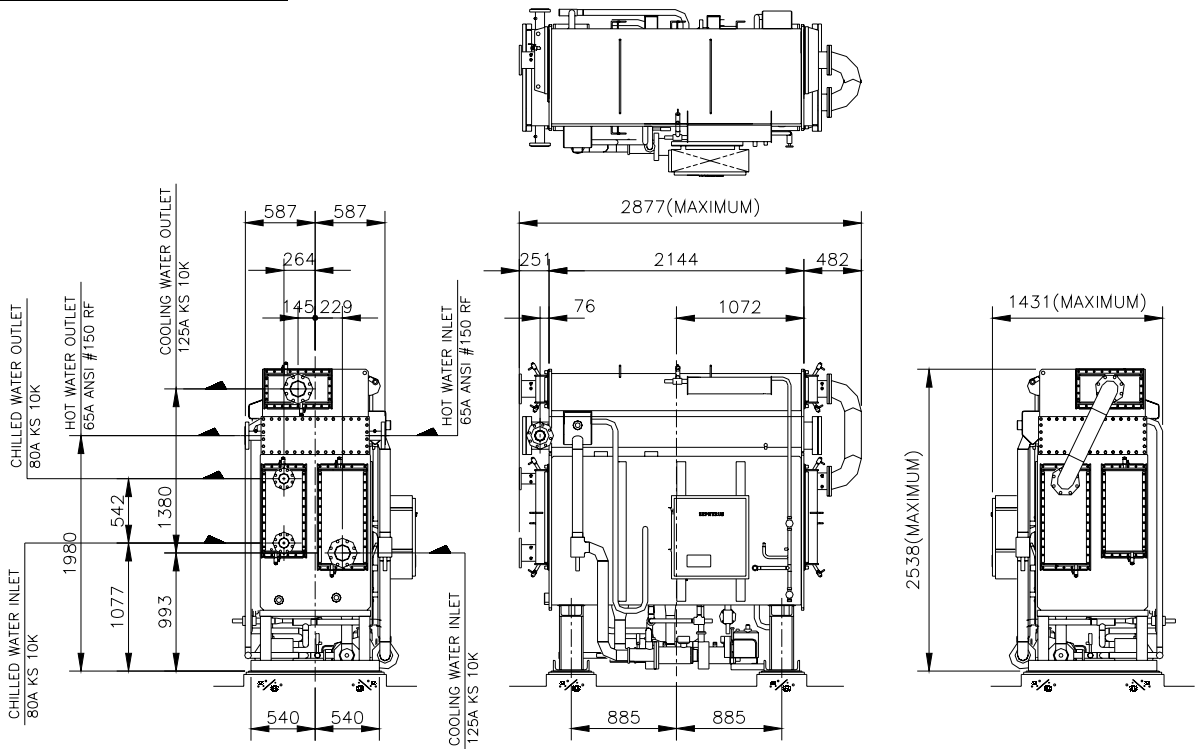

HW010G1 and 012G1

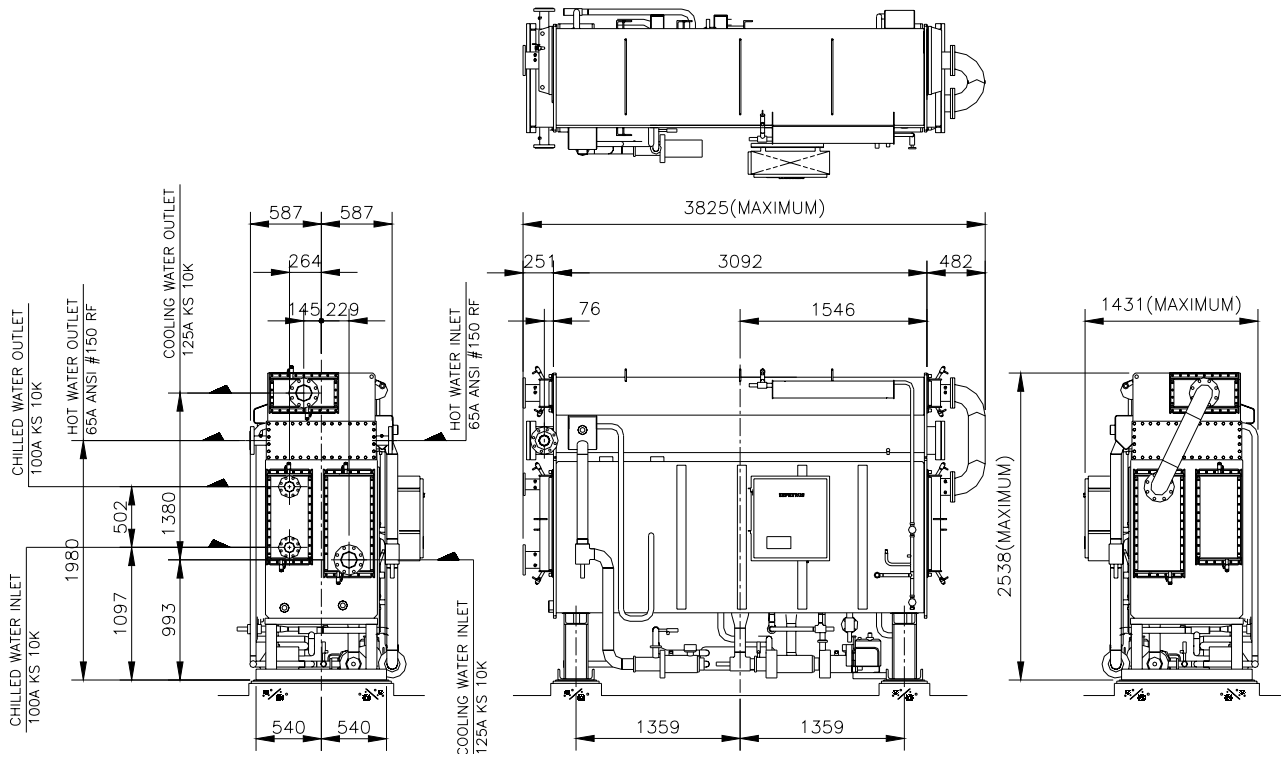

HW015G1 and 018G1

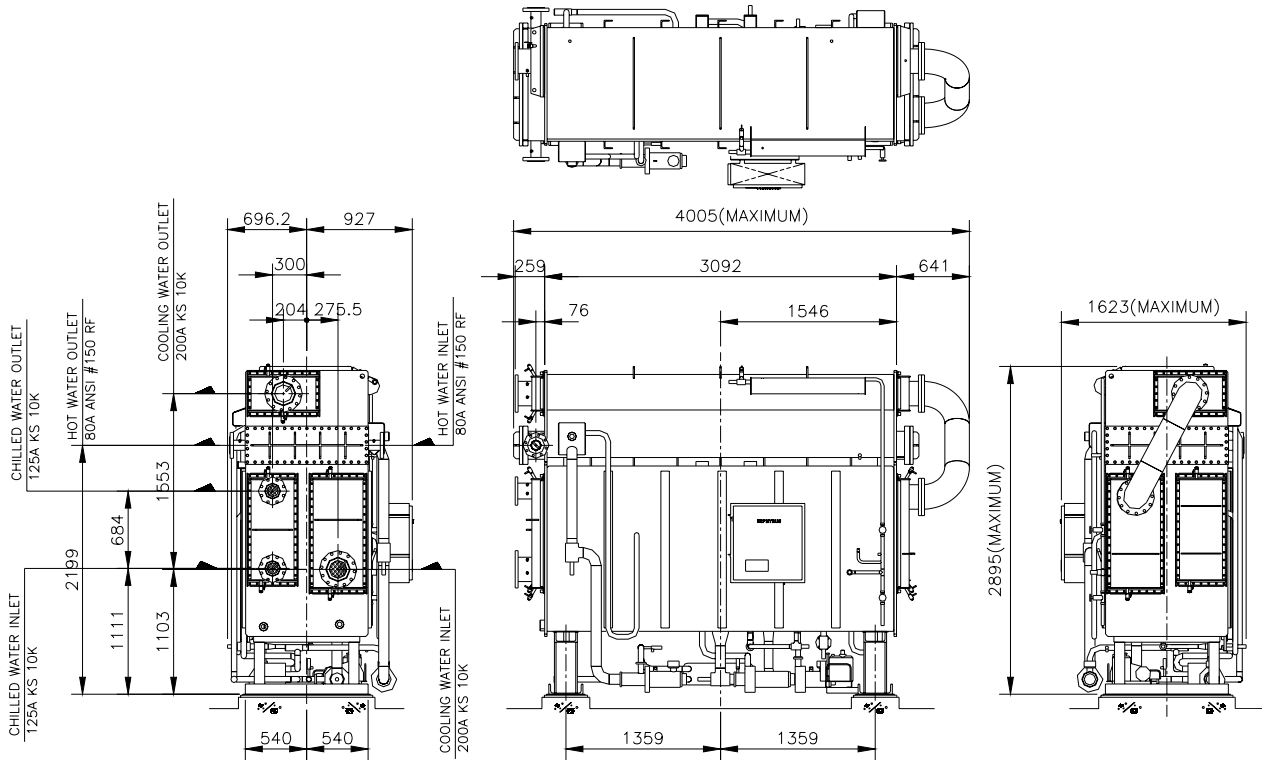

HW021G1,024G1 and 028G1

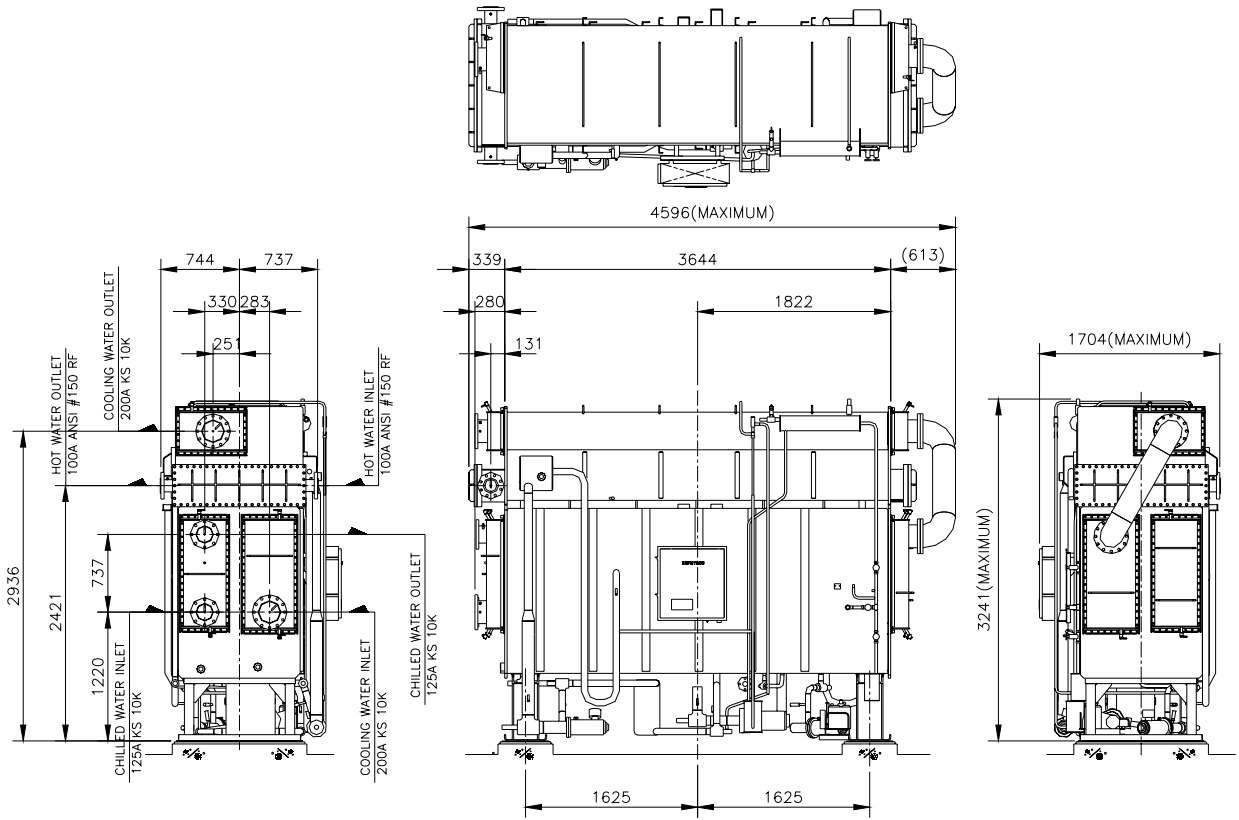

HW032G1 and 036G1

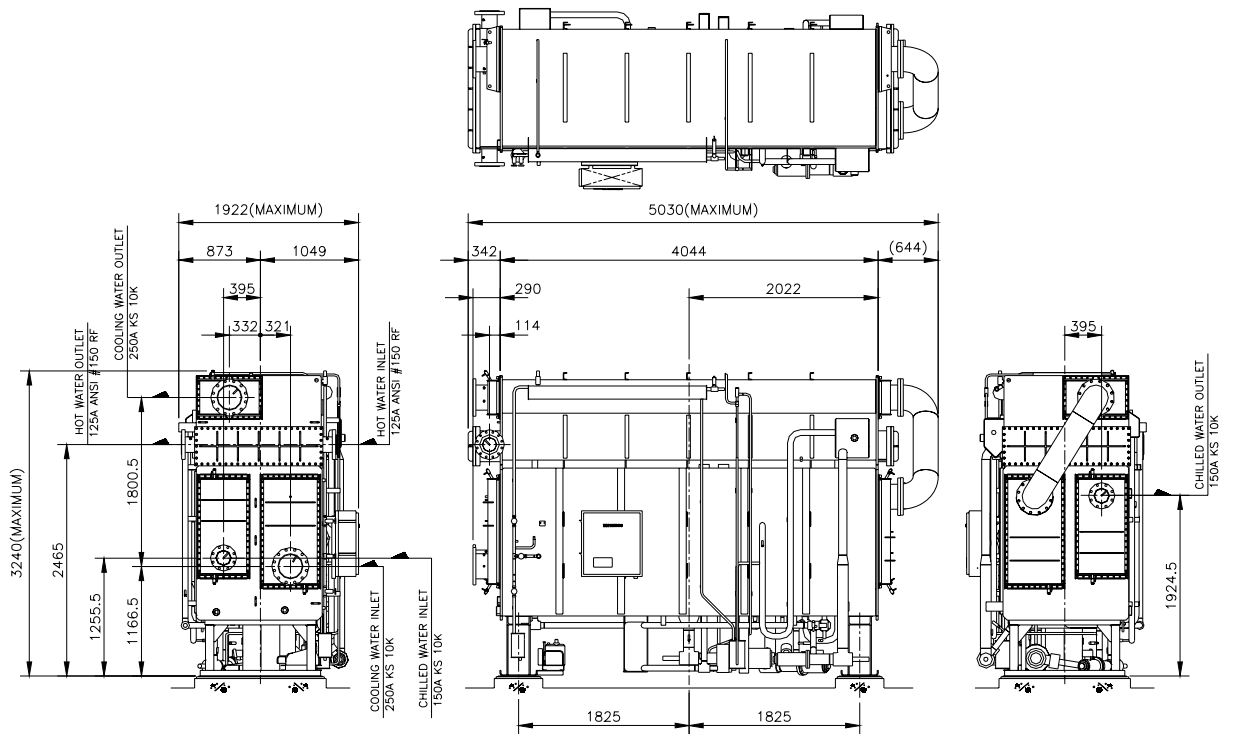

HW040G1 and 046G1

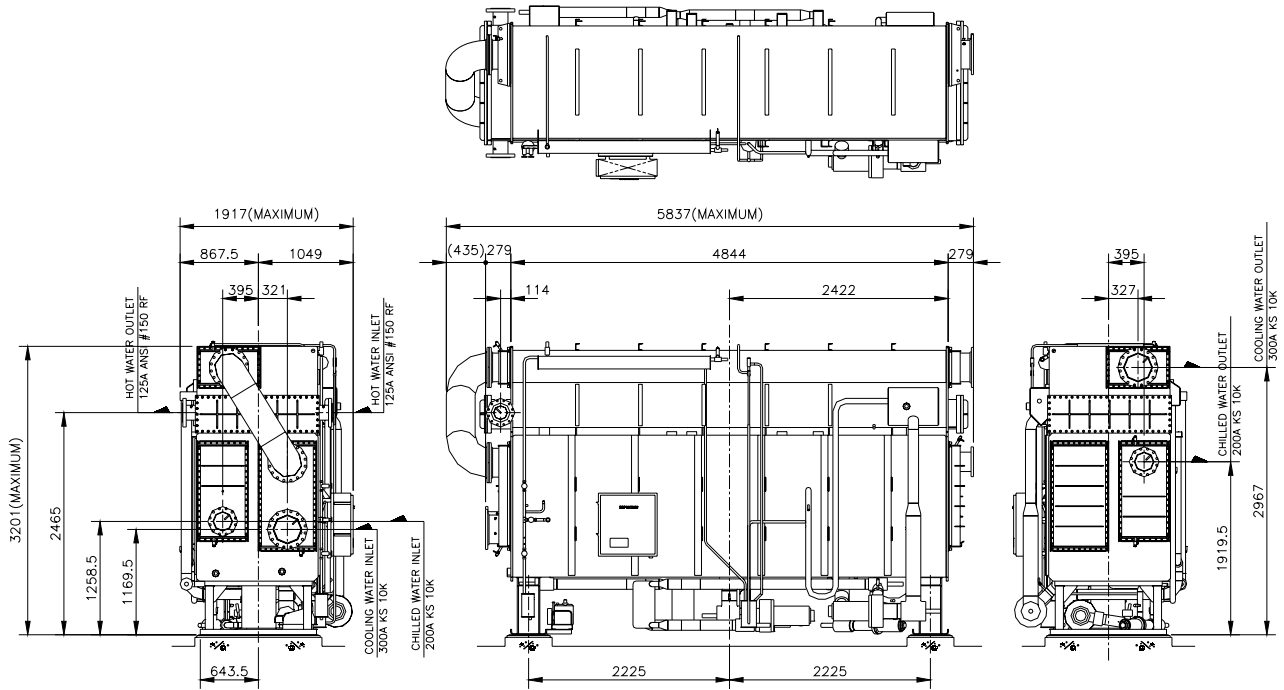

HW052G1 and 058G1

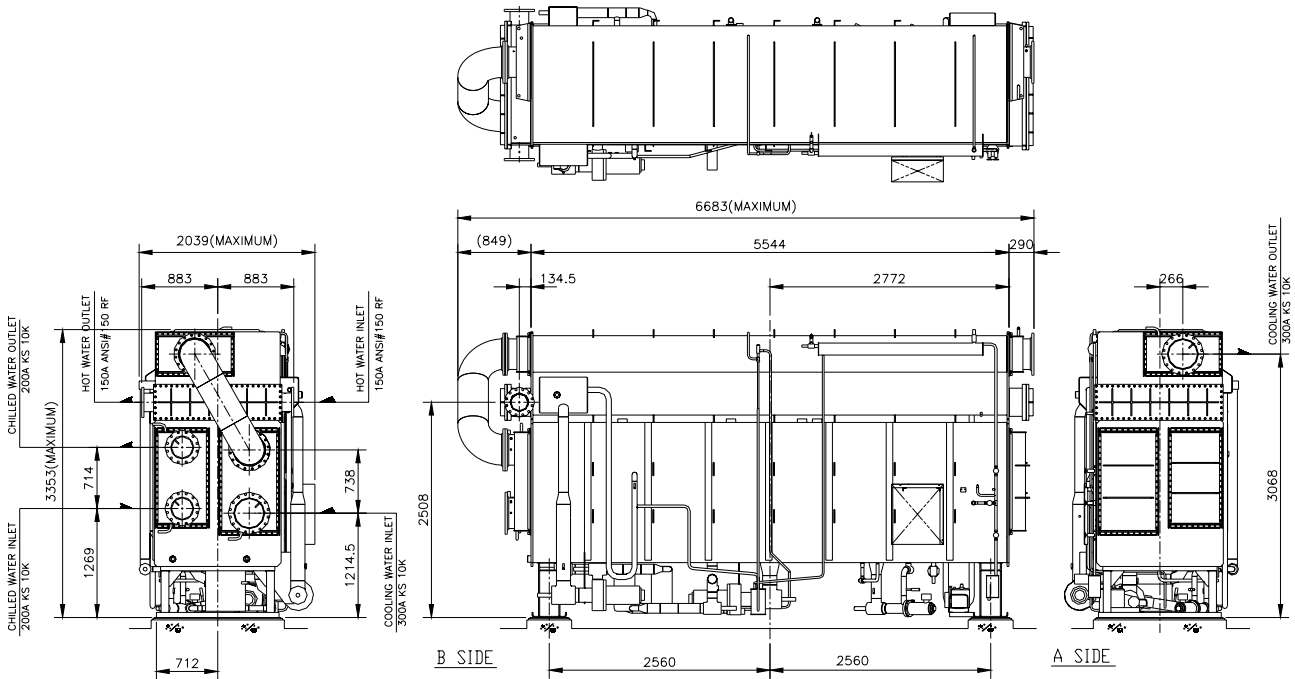

HW064G1 and 072G1

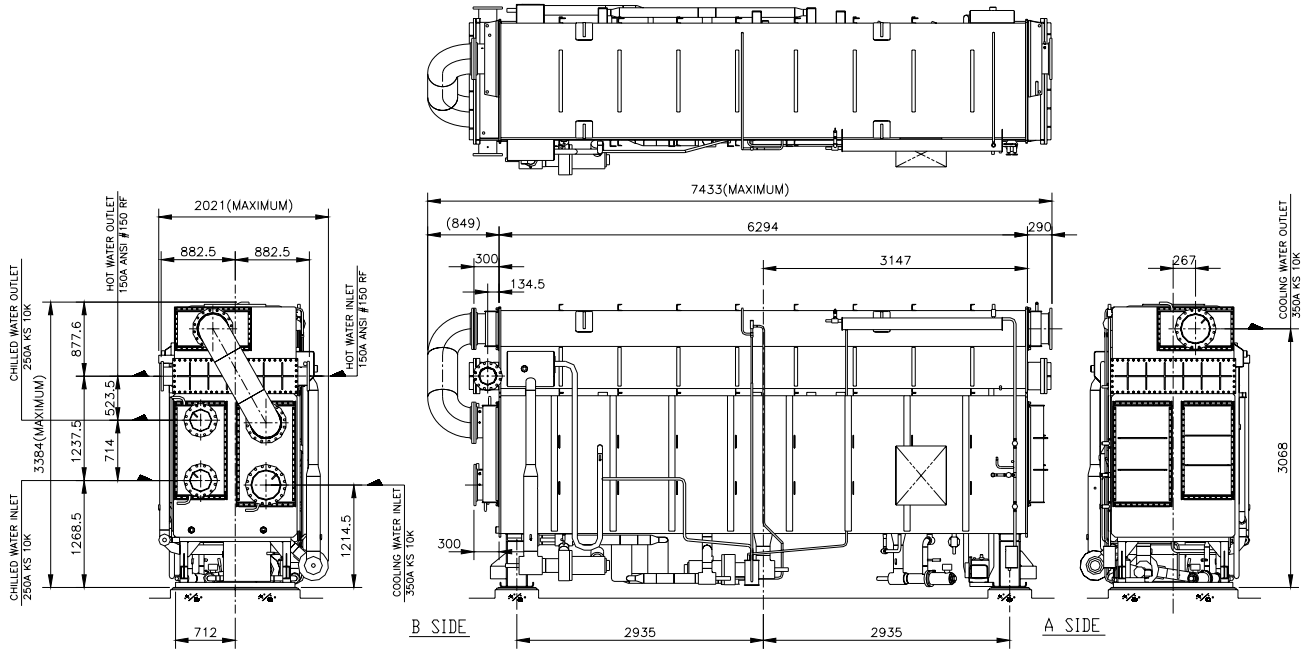

HW080G1

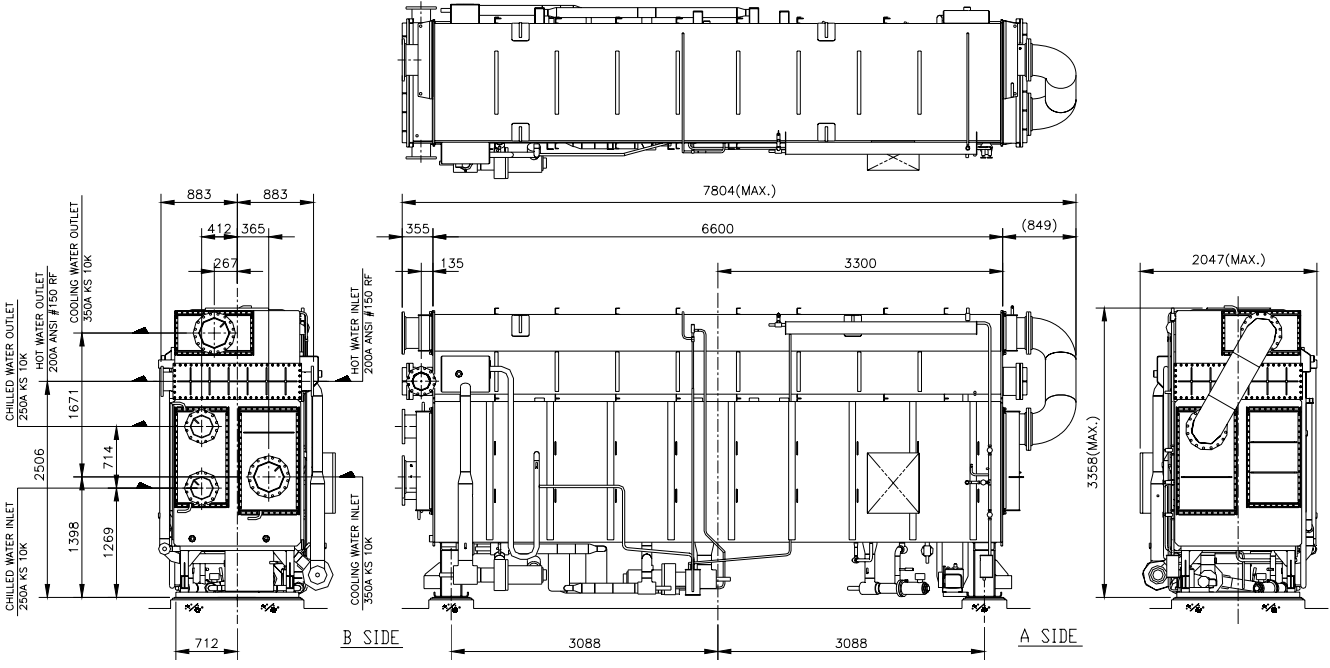

HW090G1 and 100G1

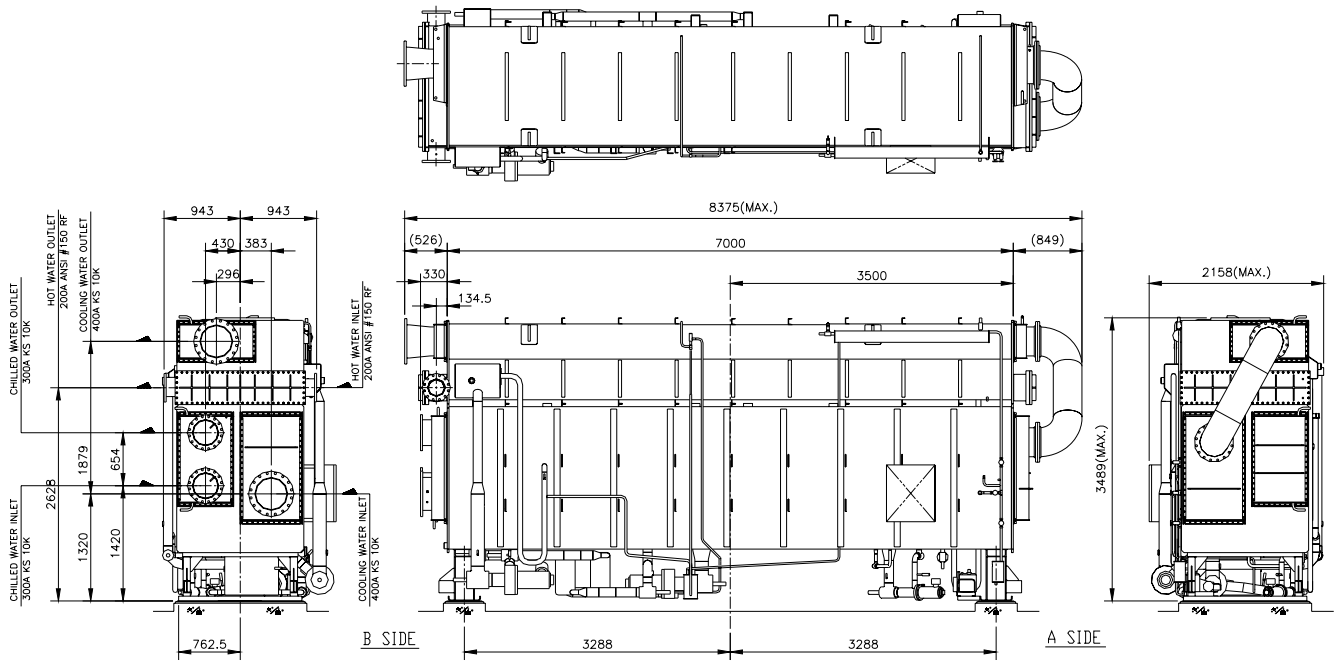

Foundation

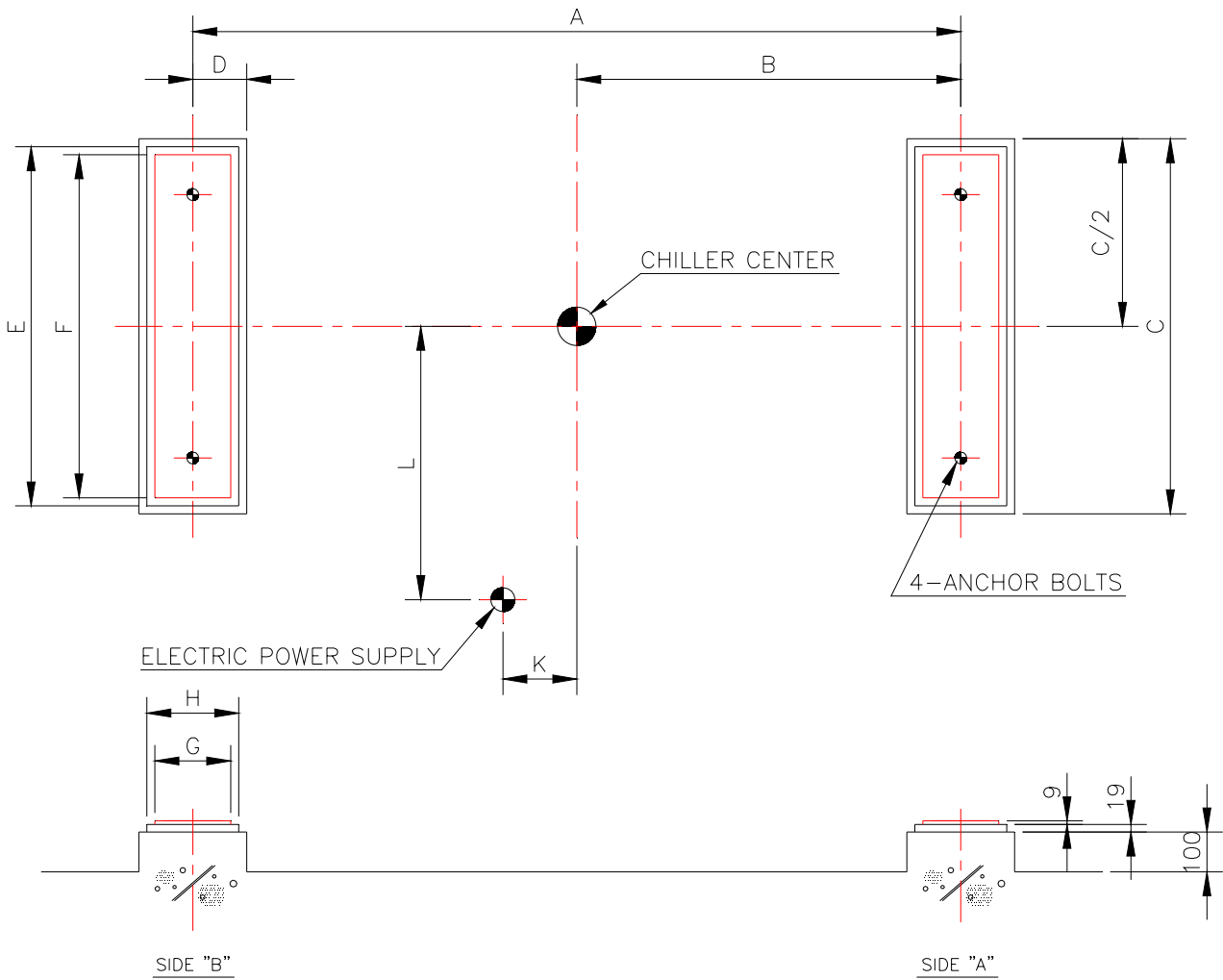

Dimension Table

Model	A	B	C	D	E	F	G	H	L	K	Remark
001/002G1	956	478	1,440	125	1,380	1,340	150	200	850	150	“-“ of K means opposite side dimension
003/004G1	970	485	1,100	190	1,060	1,020	300	340	750	50	
005G1	1,270	635	1,100	190	1,060	1,020	300	340	750	100	
006/008G1	1,770	885	1,200	190	1,160	1,120	300	340	800	-850	
010/012G1	2,718	1,859	1,200	190	1,160	1,120	300	340	800	-400	
015/018G1	2,718	1,859	1,200	190	1,160	1,120	300	340	800	-400	
021/024/028G1	3,250	1,625	1,272	240	1,232	1,192	400	440	800	0	
032/036G1	3,650	1,825	1,407	240	1,367	1,327	400	440	950	850	
040/046G1	4,450	2,225	1,407	240	1,367	1,327	400	440	950	1,100	
052/058G1	5,120	2,560	1,544	240	1,504	1,464	400	440	1,000	-1,700	
064/072G1	5,870	2,935	1,544	240	1,504	1,464	400	440	1,000	1,850	
080G1	6,170	3,085	1,544	240	1,504	1,464	400	440	1,000	2,000	
090/100G1	6,570	3,285	1,640	240	1,600	1,560	400	440	1,050	2,200	

Product specification

SAB-HW Hot water driven absorption chiller

Capacity range: 15 to 1000 tons (52 to 3516kW)

1. System description

Electronically controlled, SAB series absorption chiller utilizing hermetic refrigerant and solution pumps, lithium bromide solution as the absorbent, and water as the refrigerant. Hot water shall be supplied to the generator as the heat source.

2. Quality assurance

- A. Chiller performance shall be rated in accordance with ARI Standard 560 (latest edition).
- B. Chiller shall be manufactured in accordance with ANSI/ASHRAE 15 (latest edition), safety code for mechanical refrigeration or KS B 6271 (Korea Standard), as applicable.
- C. Chiller shall be designed and constructed to meet applicable requirements and shall bear the UL or CE label (if required).
- D. Each chiller shall undergo a series of standard factory tests to ensure that the unit is leak tight, that all electrical components operate as intended, and that every aspect of the unit fabrication meets stringent quality standards in accordance with good practice and the manufacturer's quality assurance requirements.
 1. The shell side of each chiller shall be leak tested by pressurizing to 11 psig (76 kPa) with nitrogen and then checked by spraying a soap/water mixture on all welds, tube joints, and/or gasket joints to identify any major leaks. Afterward, a mass spectrometer test shall be performed by evacuating the unit to 0.001mmHg absolute, covering the machine with a vinyl tent, and introducing helium gas under the tent. Any remaining leaks will allow the helium to be drawn into the shell side of the machine. The acceptable leak rate as measured by the mass spectrometer test shall not exceed 0.00002 cc/sec standard air.
 2. The tube side of the evaporator, absorber, and condenser shall be hydrostatically tested at 1.5 times rated design pressure and held for one hour.
 3. The refrigerant and solution pump/motors shall undergo standard factory tests to ensure proper head flow, and motor output characteristics.
 4. All machine wiring shall undergo an insulation resistance test. The chiller control center and

all electrical components shall also be functionally tested to verify continuity and proper electrical operation.

5. Final assembly inspection shall consist of verifying that all valves, controls, instrumentation, pumps, purge components, and all other machine components have been properly installed on the machine.
6. Each unit shall then be checked for overall appearance and dimensional accuracy.
7. Final inspection shall be performed on each unit to check that painting of the unit is as specified, name-plate data is correct, and that all accessories are furnished as required.

3. Equipment

A. General:

Absorption liquid chiller shall include evaporator, absorber, condenser, generators, solution heat exchanger, refrigerant/solution pumps, purge system, piping, wiring, controls and auxiliaries. Shipment of the machine shall be in one piece. Initial charge of lithium bromide can be included with the chiller for charging at the jobsite.

B. Heat exchangers:

1. All heat exchangers shall be of shell and tube construction with shells, tube sheets, tube support sheets, and water boxes fabricated of carbon steel. All heat exchangers shall incorporate straight tubes. All tubes shall be rolled into grooveless tube sheets and expanded into tube support sheets, except for the generator tubes. The generator tubes shall be rolled into grooved tube sheets and expanded into tube support sheets
2. The evaporator, absorber, condenser and generator water boxes shall be designed for 114 psig (785 kPa) working pressure. Nozzle-in-head (NIH) type water boxes shall be supplied on the evaporator and absorber-condenser while the generator water boxes shall be marine type. All water boxes shall be provided with vent and drain connections. ANSI 150 psig RF flanges shall be furnished on generator water box nozzle connections.
3. A solution heat exchanger shall be an integral part of the machine to increase efficiency by pre-heating weak solution on the tube side with strong solution on the shell side. It shall be a wide use copper brazed type plate heat exchanger and fabricated of a corrosion-proof material (stainless steel).

4. Tray and dripper system for the evaporator and absorber shall be of a non-clogging design, specifically designed for the intended duty, and shall be fabricated of a corrosion-proof material to ensure continuous, high-efficiency operation.
5. Heat exchanger tube material and minimum wall thickness shall be contingent on the type of corrosion inhibitor used in the machine. For **lithium nitrates** systems, the following tube specifications shall apply to ensure long machine life and continuous operation:
 Evaporator.....Copper,Endcrossed-ridge
 Absorber.....Copper,Endcrossed
 Condenser.Copper, Bare
 Generator.....Copper,Endcrossed-ridge

* Special tube material like Cupronickel, Titanium can be used as option, if required.

C. Pumps/Motors:

Refrigerant and solution pumps/motors shall be self-contained, leakproof, hermetic type, with isolation valves, and internal seal water system to minimize air leakage into the machine. Lubrication and cooling shall be accomplished by the fluid being pumped; auxiliary water piping for cooling and lubrication shall not be acceptable. Pump/motor assemblies shall be designed for a minimum of 5 years (or 20,000 hours) normal operation between inspections.

D. Purge system

An automatic purge system shall be furnished to provide a continuous purging action whenever the chiller is in operation to assure long machine life and efficient performance. Non-condensable gas shall be removed from the absorber by a liquid ejector, which shall use flow from solution pump to create a suction. Non-condensable gas shall be stored external to the unit and shall be prevented from diffusing back into the machine when the unit is not operating. Evacuation of the external storage tank shall be accomplished by the use of a unit-mounted vacuum pump. The vacuum pump shall be factory mounted on the chiller and wired to the control panel by the chiller manufacturer.

E. Controls:

1. General

The Hot water absorption chiller contains a microprocessor-based control panel that

monitors and controls all operations of the machine. The microprocessor controls system matches the cooling capacity of the machine to the cooling load while providing state of machine protection. The system controls cooling capacity within the set point plus the dead band by sensing the leaving chilled water and regulating the hot water control valve via a mechanically linked actuator motor.

The control system controls the operation of the machine by monitoring all operating conditions. The microprocessor control panel can diagnose a problem and let the operator know what the problem is and what to check. It promptly positions the hot water control valve to maintain leaving chilled water temperature. It can interface with auxiliary equipment such as pumps and cooling tower fans. It continually checks all safeties to prevent any unsafe operating condition.

2. Safety control

The Control panel monitors all safety control inputs and if required shuts down the chiller or stops solution pump to protect the chiller from possible damage from any of the critical conditions. The controller screen displays the messages if the controller starts safety controls to stop, the alarm relay operates and alarm indicator is brink. The alarm is saved in the controller alarm table to correct the problems.

3. Remote start/Stop control

A remote device, such as a time clock which uses a set of contacts, may be used to start and stop the chiller.

4. Spare safety inputs

Normally closed (NC) digital inputs for additional field-supplied safeties may be wired to the spare protective limits input channel in place of the factory-installed jumper. (Wire multiple inputs in series.) The opening of any contact will result in a safety shutdown and controller display.

5. Tower-fan relay

The tower-fan relay can be controlled when cooling water inlet temperature is low. The temperature setting point is adjustable in the range 60 ~ 85°F.

6. Auto restart after power failure
If the control power is interrupted during operation, the chiller stops immediately without the normal shutdown sequence and dilution. Solution crystallization can occur if the concentration is high (chiller was operating with a relatively large load). The machine will start automatically when the power is back on.
- F. Machine safety devices:
1. Machine safety and limit devices shall be included as follows:
 - a. Low chilled water temperature
 - b. Low chilled water flow
 - c. Low cooling water flow (optional)
 - d. High generator temperature
 - e. High motor winding temperature – refrigerant / solution pump
 - f. High motor amperage – refrigerant / solution pump
- G. Electrical requirements:
1. Power supply to the unit shall be 3-ph, 60Hz with voltages of 208, 230, 460, or 575, 3-ph, 50Hz with 220V, 380V, 400V or 440V as specified on the equipment schedule. A multi-tap transformer shall provide 100, 110 or 200, 220 single-phase secondary power for the control panel
 2. Contractor shall supply and install the electrical power line and all auxiliary electrical protection devices per local code requirements and as indicated necessary by the chiller manufacturer.
- H. Contractor shall supply and install electrical wiring and devices required to interface the chiller controls with the building control system, if applicable.
- I. Piping requirements:
1. Piping and instrumentation for the chilled water, cooling water and hot water shall be supplied and installed by the contractor / owner.
 2. Chilled water flow switch shall be factory supplied and factory installed in the evaporator water nozzle. Cooling water flow switch shall be field installed or factory installed if customer requires and supplied by either the chiller manufacturer or the contractor/owner.
- J. Thermal insulation:
Insulation of cold or hot surfaces shall be field supplied and field installed on the machine. Chiller manufacturer shall specify the recommended material and surface area to be insulated.
- K. Sound level:
The overall sound pressure level of the chiller shall not exceed 75 dbA when measured per ARI Standard 575 (latest edition).
- L. Start-up:
1. Unit manufacturer shall provide a factory-trained service representative, employed by the chiller manufacturer, to perform and/or supervise chiller pressure test (when required), charge chiller with refrigerant (water) and lithium bromide solution, place unit into operation, and calibrate all controls in accordance with the manufacturer's written start-up, operating, and maintenance instructions.
 2. After unit start-up has been performed, the same factory representative shall be available for a period of instruction (not to exceed 4 hours) to instruct the owner's personnel in the proper start-up, operation, and maintenance procedures.
 3. Manufacturer shall provide the following literature:
 - a. Installation Instructions
 - b. Start-up, operating and maintenance instructions
 - c. Field wiring diagrams
- M. Options and accessories:
1. High-pressure waterboxes:
Waterboxes rated for 250 psig (1724 kPa) or 300 psig (2068 kPa) working pressure shall be furnished when specified on the equipment schedule.
 2. Special tubing:
Tubing of non-standard materials and/or wall thickness shall be provided when specified on the equipment schedule.
 3. Isolation package:
A vibration isolation package consisting of machine soleplates and neoprene isolation pads shall be furnished for field installation when specified on the equipment schedule.
 4. Cooling water flow switch:
A cooling water flow switch, rated for either 150 psig (1034 kPa) or 300 psig (2068 kPa) shall be field installed or factory installed if customer requires and supplied by either the chiller manufacturer or the contractor/owner.

Piping & Instruments

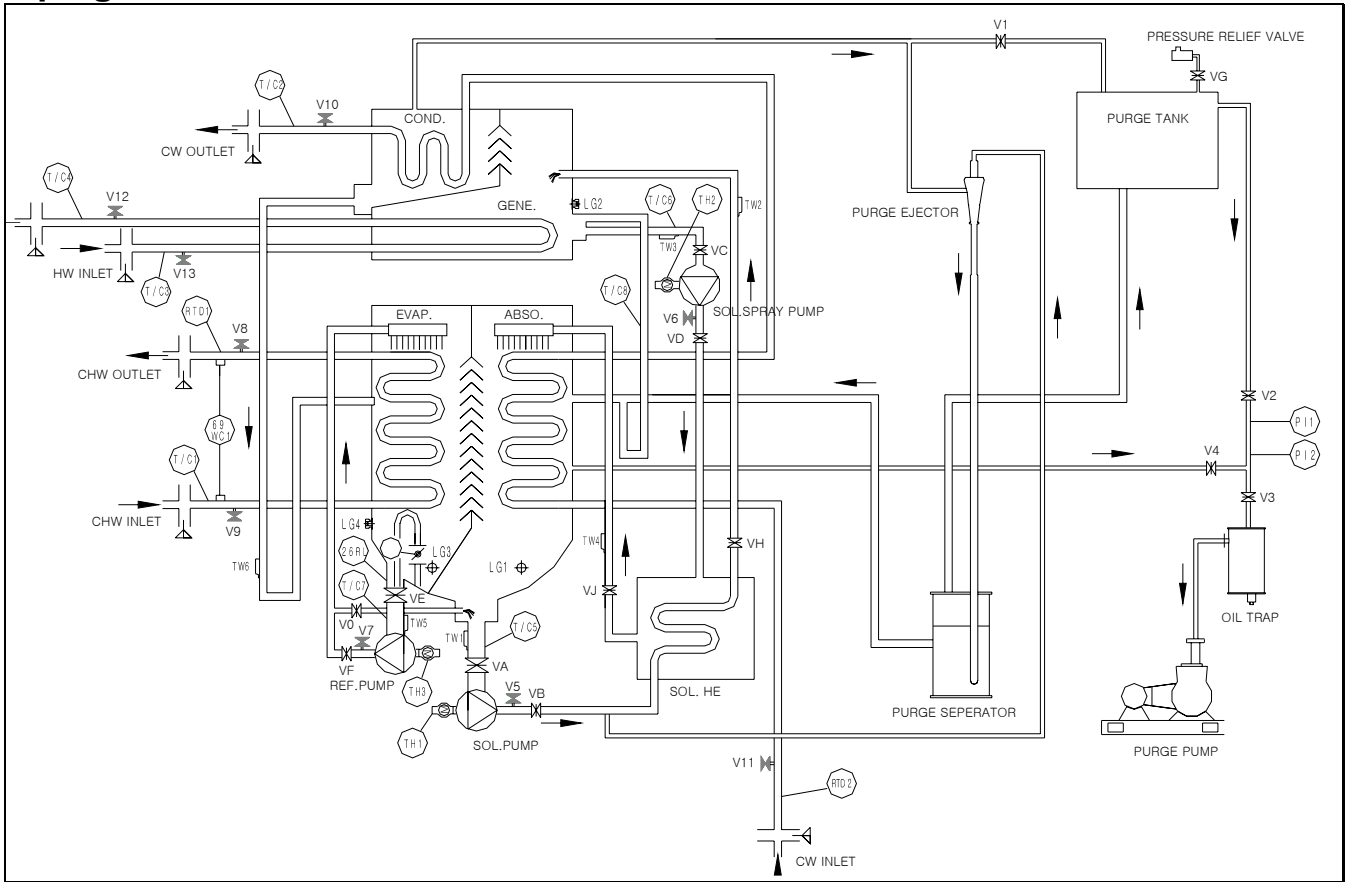

Mark Table

Mark	Part Name	Purpose
26RL	Refrigerant Subcooled Relay	Protection of EVAP. tube from refrigerant frozeed.
69WC1	Chilled Water Flow cut Relay	Protection of EVAP. tube from chilled water frozeed.
TH1	Solution Pump Over Current	Protection of solution pump motor from over current and overheat
TH2	Solution Spray Pump Over Current	Protection of solution spray pump motor from over current and overheat
TH3	Refrigerant Pump Over Current	Protection of refrigerant pump motor from over current and overheat
RTD1	Resistor Temp. Sensor	Temp. sensing of chilled water outlet
RTD2	Resistor Temp. Sensor	Temp. sensing of cooling water inlet
T/C1	Thermistor	Temp. sensing of chilled water inlet
T/C2	Thermistor	Temp. sensing of cooling water outlet
T/C3	Thermistor	Temp. sensing of hot water inlet
T/C4	Thermistor	Temp. sensing of hot water outlet
T/C5	Thermistor	Temp. sensing of solution outlet from absorber
T/C6	Thermistor	Temp. sensing of solution outlet from generator
T/C7	Thermistor	Temp. sensing of refrigerant outlet from evaporator
T/C8	Thermistor	Temp. sensing of solution overflow from generator and prevent solution crystallized
VA	Cut Off Valve	Maintenance for solution pump
VB	Cut Off Valve	Maintenance for solution pump.
VC	Cut Off Valve	Maintenance for solution spray pump
VD	Cut Off Valve	Maintenance for solution spray pump
VE	Cut Off Valve	Maintenance for refrigerant pump
VF	Cut Off Valve	Maintenance for refrigerant pump
VG	Cut Off Valve	Maintenance for pressure relief valve
VH	Flow Control Valve	Flow control of solution from absorber
VJ	Flow Control Valve	Flow control of solution from generator

Controls

Microprocessor-based unit controller is factory mounted, wired and tested to ensure a protection of the machine and efficient capacity control. The program logic provides proper Start/Stop of the machine and also enables a communication interface with others.

Component test and diagnostic check

- Touch screen interface for status display, set-point control, and system configuration
- Primary and secondary status messages
- Individual Start/Stop schedules for local mode
- Recall of up to 999 alarm and alert messages with diagnostic help
- Extensive diagnostic and service capabilities
- Advanced crystallization protection

Safety cutouts

- Solution pump motor overload/high temperature
- Refrigerant pump motor overload/high temperature
- Low chilled water temperature cutout
- Low refrigerant temperature cutout
- Low cooling temperature cutout
- Low chilled water flow cutout
- Low cooling water flow cutout (Option)
- Generator high temperature cutout
- Hot water high temperature cutout

Protective limits

- Strong solution leaving high temperature generator alarm
- Hot water high temperature alarm
- Refrigerant pump overload/high temperature alarm
- Solution pump motor overload/high temperature alarm
- Low refrigerant temperature alarm
- Low chilled water temperature alarm
- Low cooling water temperature alarm
- Low chilled water flow alarm

Overrides

- Hot water high temperature
- Generator solution high temperature
- High concentration

Temperature sensor faults

- Leaving chilled water temperature
- Cooling water temperature entering absorber
- Refrigerant condensate temperature from condenser
- Refrigerant evaporating temperature
- Strong solution temperature leaving generator
- Entering hot water temperature

Capacity control

- Leaving chilled water control
- Running travel limit (control valve opening limit)

Indications

- Chiller operating status message
- Absorption cycle state points
- Dilution cycle
- Power-on
- Alarm
- Safety shutdown message
- Run hours
- Control valve position



Controller



Touch Screen Display



Control Panel

Start-up sequence

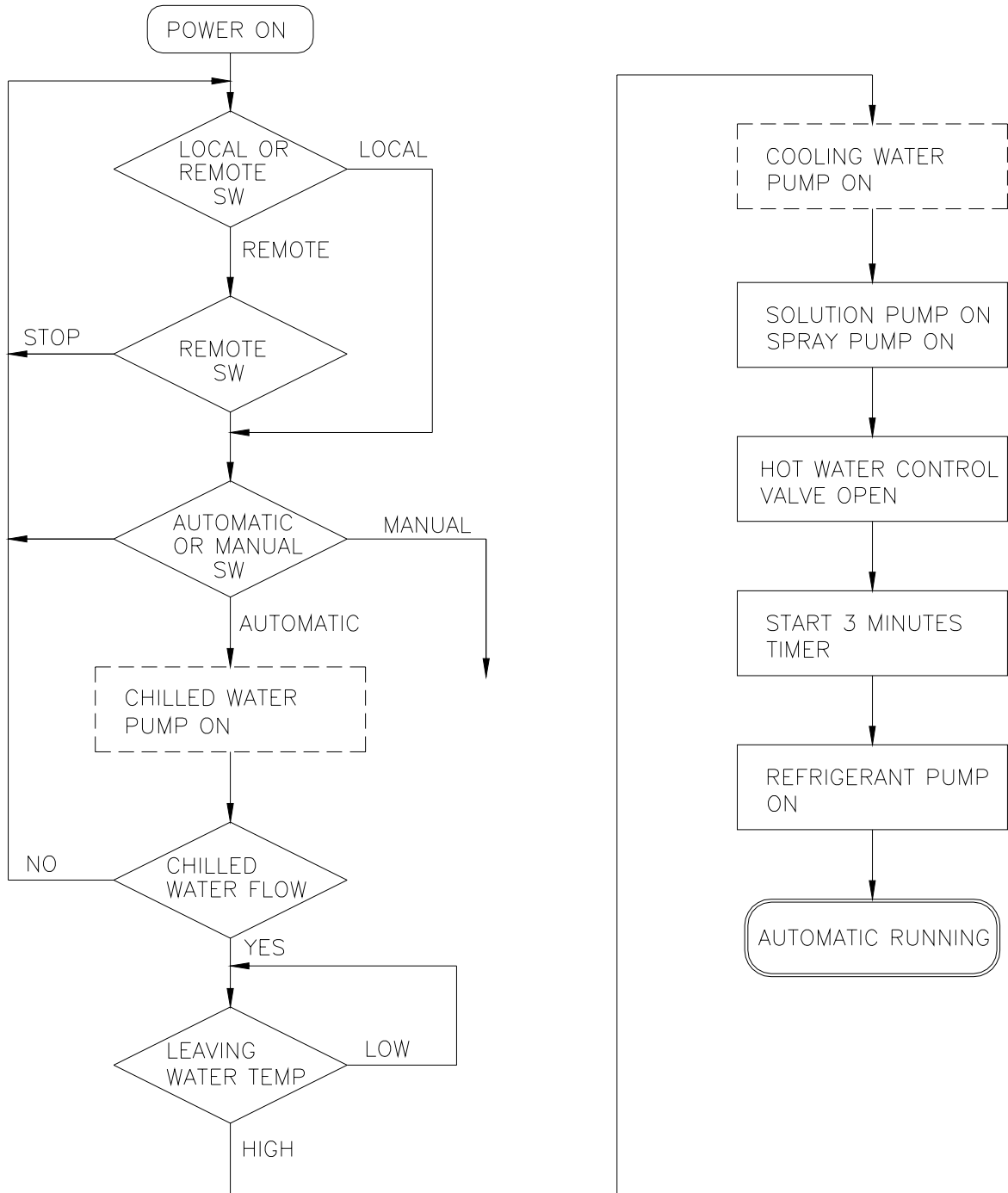

Start-up time chart

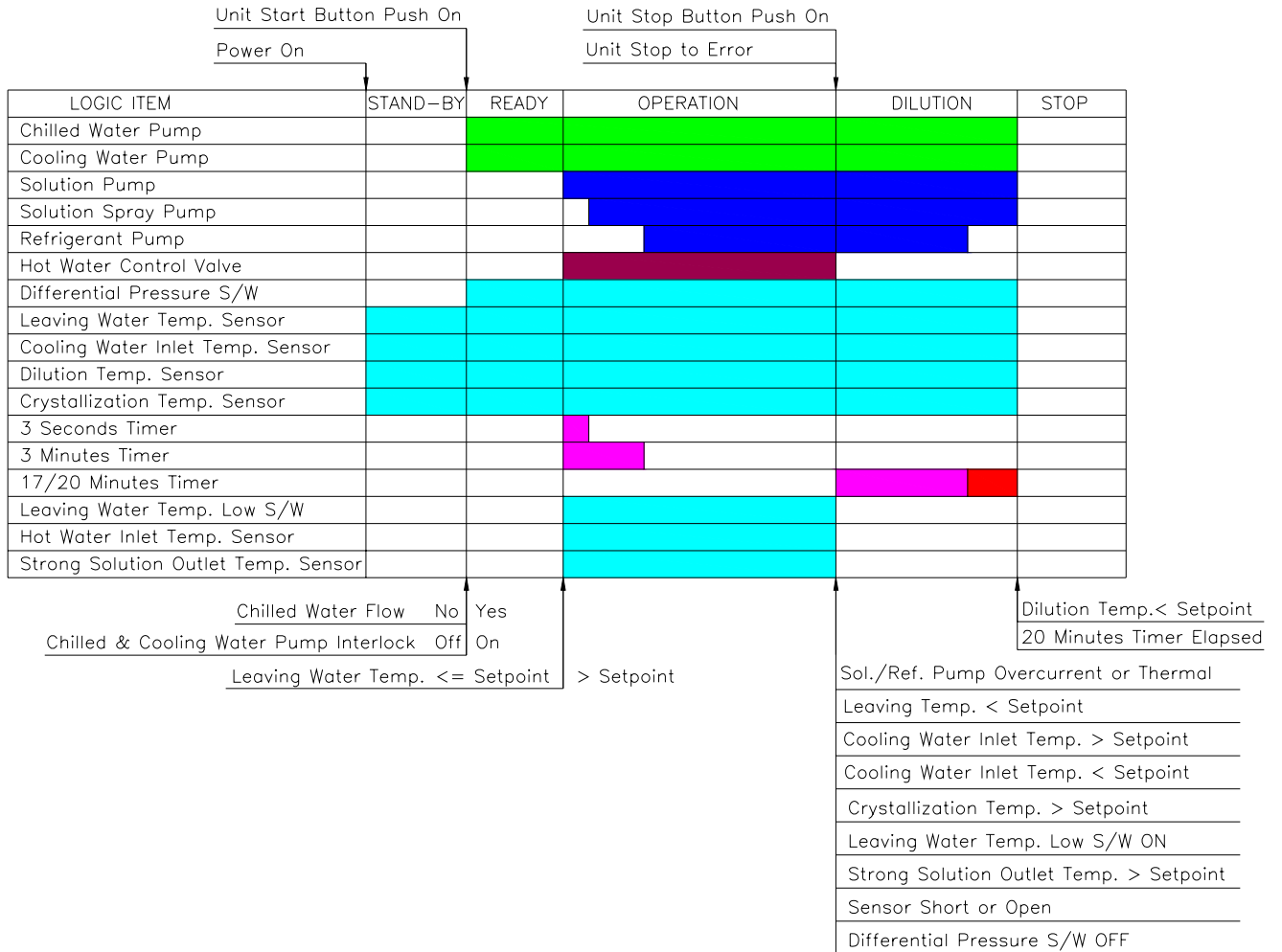

Control panel – outside view

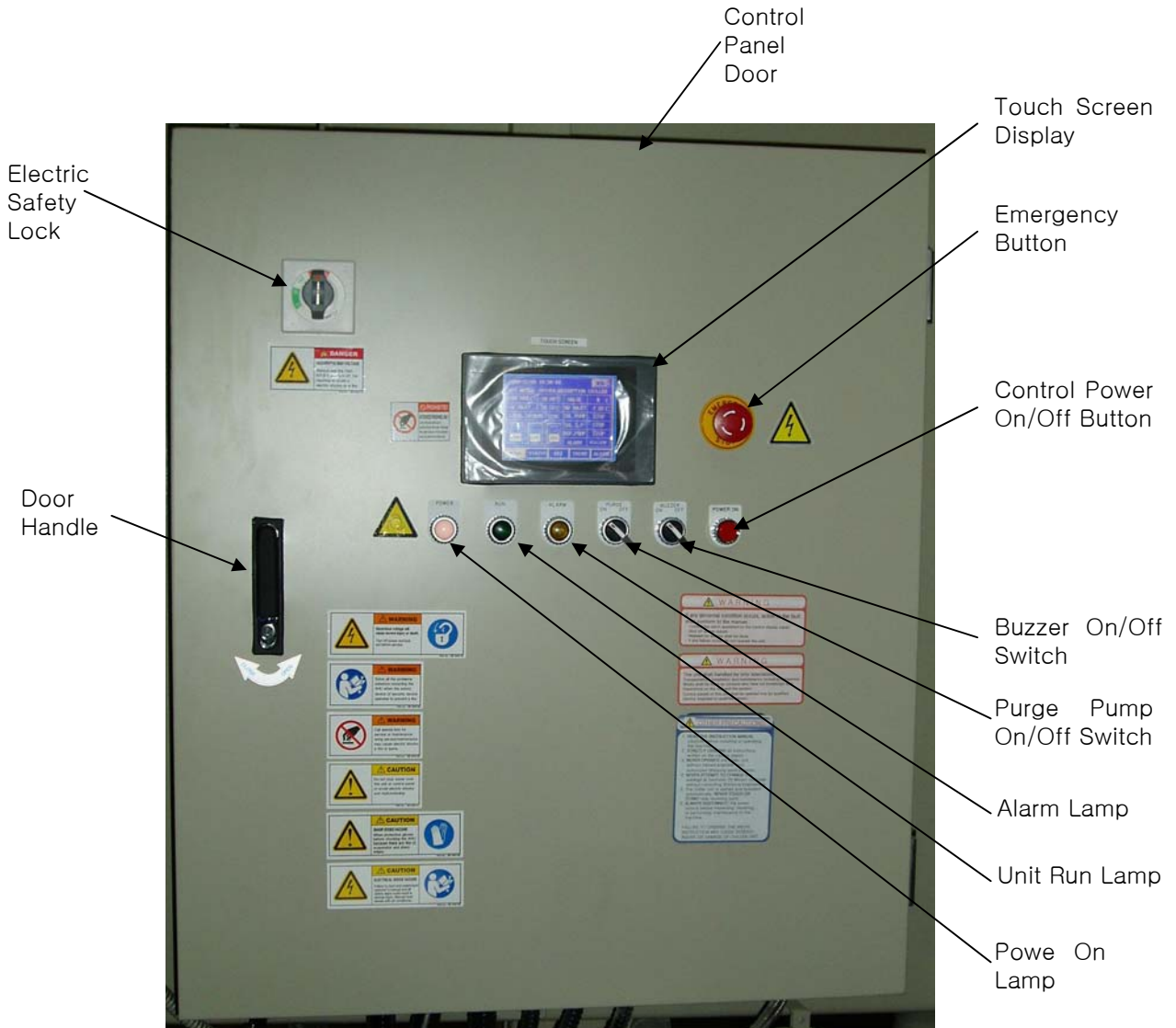

Control panel - inside view

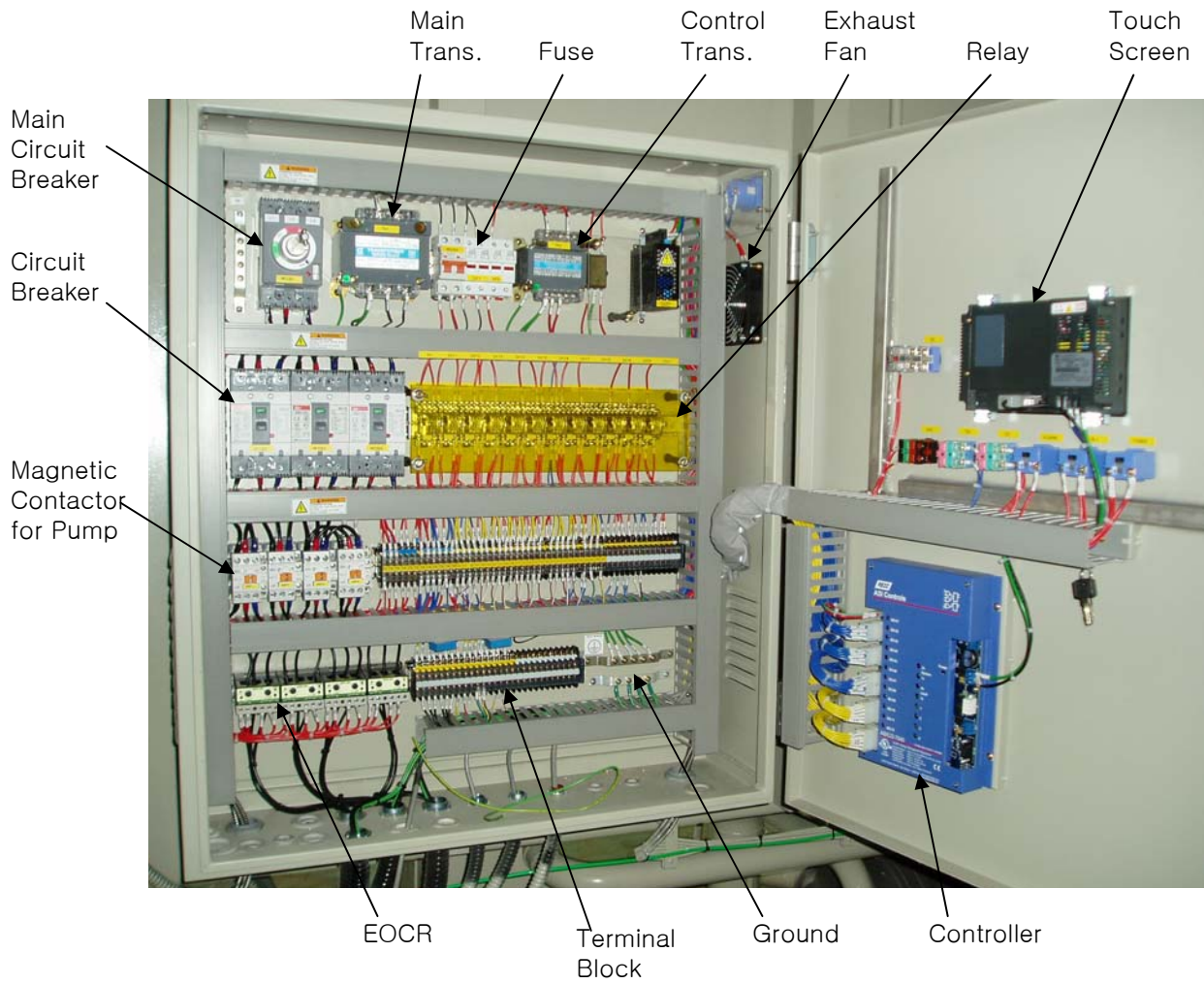

Electric data

Model	Main Power (kVA)	Output (kW)	Rated Current(A)	Power Cable(mm ²)	Ground (mm ²)	Remark
001/002G1	4.2	1.3	5.1	4	4	
003-005G1	4.4	2.1	8.1	4	4	
006/008G1	4.8	2.7	10.1	4	4	
010/012G1	9.1	5.0	15.1	6	6	
015/018G1	9.8	5.4	15.1	6	6	
021-036G1	14.4	8.1	22.1	10	10	
040/046G1	20.4	11.6	34.1	10	10	
052/058G1	20.4	11.6	34.1	10	10	
064/072G1	23.5	13.4	40.6	16	16	
080G1	26.4	15.1	45.5	16	16	
090/100G1	29.8	17.1	63.6	25	16	

*UL 1007/1015 Cable standard

Hot water control valve

The three-way hot water control valve is supplied from factory. But, this hot water control valve is installed in the inlet or outlet line of hot water at jobsite. The valve has a carbon steel body with DIN type flanged end connections. The valve size is changed 1 1/2 to 6 in., depending on the machine model or the specific job requirements. The electric actuator of valve is operated with 24VAC and controlled with 4 to 20mA DC signal. And, the electric power 24VAC and the control signal are supplied from the chiller control panel. The hot water pipes have to be correctly connected according to the flow direction marked at the side of valve body, whether it is used as mixing type or diverting type.

DN	A	B	C	D	D2	D4	E	K	P	Q	R	S	T	H
1	6.30	13.15	3.15	4.53	0.55(4x)	2.56	0.63	3.35						>21.02
1 1/2	7.87		3.94	5.91		3.31	0.71	4.33						>21.22
2	9.06	13.35	4.53	6.50	0.75(4x)	3.90	0.79	4.92	11.81	5.00	4.13	2.50	4.72	>22.05
2 1/2	11.42		5.71	7.28		4.65	0.87	5.71						>26.22
3	12.20	14.17	6.10	7.87		5.20	0.87	6.30						>26.65
4	13.78	18.43	6.89	8.66	0.75(6x)	6.14	0.94	7.09	14.76	7.01	5.39	3.50	5.00	>27.28
5	15.75	18.86	7.87	9.84		7.24	1.02	8.27						>27.28
6	18.90	19.49	9.45	11.22	0.91(6x)	8.31		9.45						>27.28

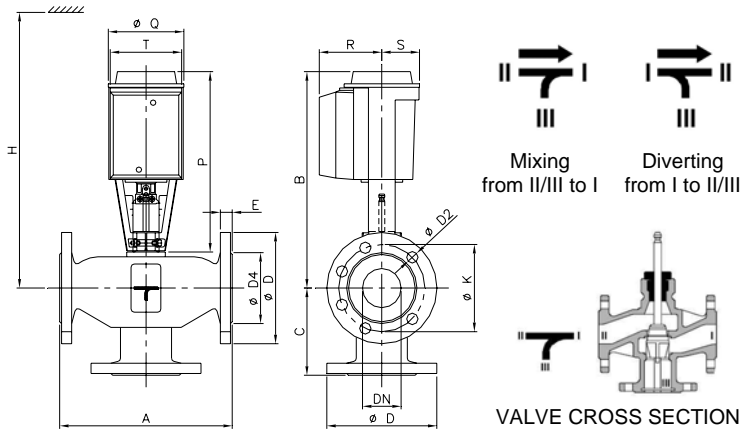

Thermal insulation – Surface area

The cold and hot machine surfaces have to be thermally insulated after the initial operation at jobsite. Thermal insulation drawings will be submitted in details. Non-inflammable Polymer sponge usable at 248°F(120°C) or incombustible Glass wool should be used for cold and hot surfaces. When glass wool is used, it is wrapped with thin aluminum plate or galvanized steel plate. The motor section of refrigerant pump is not insulated and the insulations on water box sections should be disassembled for the repair. The final finish painting is performed after the insulation work. The insulation work and the final finishing paint could be performed as the optional works after factory testing.

Model	Hot Surface(ft ²)		Cold Surface(ft ²)	
	2inch (1 1/2inch)	1inch (3/4inch)	3/4inch	3/8inch
001/002G1	30	13	21	7
003/004G1	31	18	28	13
005G1	40	22	39	13
006/008G1	51	30	52	15
010-018G1	78	30	73	15
021-028G1	102	32	129	16
032/036G1	122	37	153	18
040/046G1	141	38	178	18
052/058G1	167	45	216	21
064/072G1	187	45	242	23
080-100G1	208	56	269	27

*Number in () is insulation thickness of polymer spoge.

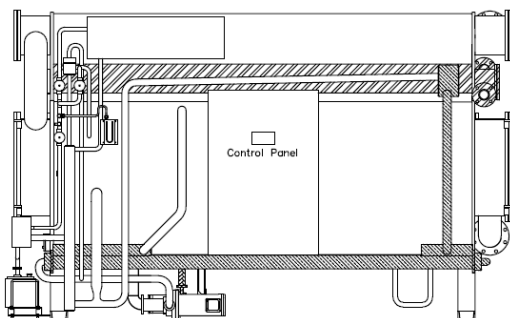

INSULATION FOR HOT SURFACES

- 2 in(1 1/2 in) : Genarator and It's Water Box
- 1 in(3/4 in) : Heat Exchanger Body and It's Piping

* () is Thickness of polymer sponge

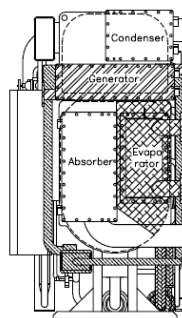

INSULATION FOR COLD SURFACES

- 3/4 in : Evaporator Body and It's Water Box
- 3/8 in : Inlet and Outlet Piping of Refrigerant Pump

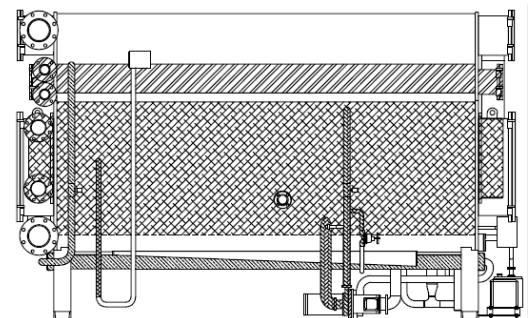

Typical piping & Wiring

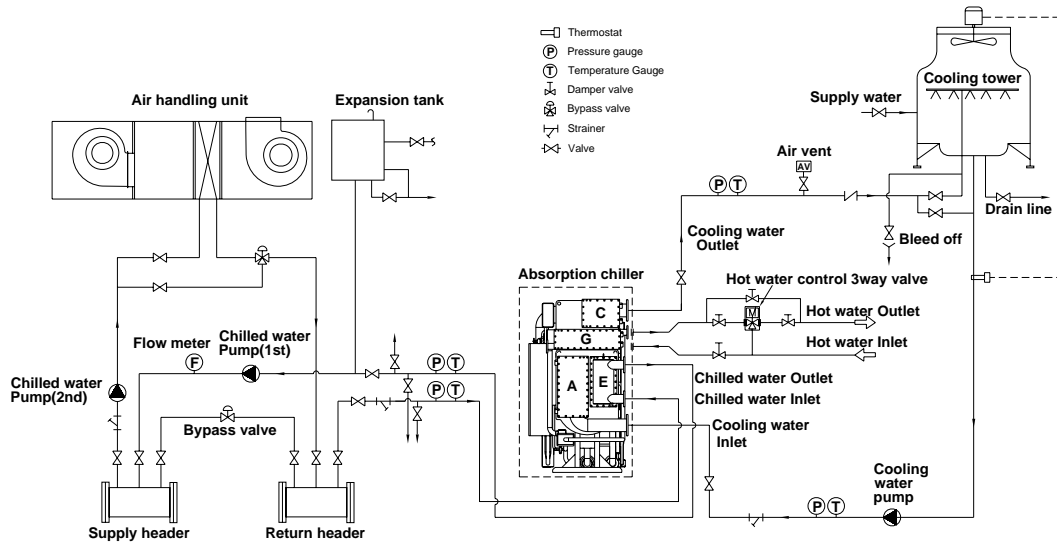

- 1) All external equipment out of dotted line is the scope of customer's.
- 2) Refer to outline drawing and specification data sheet for the external dimensions of the machine, the location & the diameter of water pipe connection and etc.
- 3) Driving hot water must be maintained as design temperature.
- 4) The stop valves at hot water inlet and outlet pipe shall be installed.
- 5) The locations of the chilled water pumps, cooling water pumps and expansion tanks shall be determined in consideration of the hydrostatic head of pumps and the height of building. And the Machine shall not be subject to a pressure larger than the designed pressure at any water headers.
- 6) For cooling water quality control, it is recommended to install cooling water bleed-off device on the inlet pipe line of cooling towers.
- 7) About 10 meshes of strainers shall be installed in the cooling water line.
- 8) For the maintenance and the inspection of the Machine, the following equipment shall be installed on each chilled water and cooling water inlet/outlet lines as well as stop valve.
 - Thermometers and pressure gauges shall be installed at chilled and cooling water inlet/outlet.
 - Air relief valves shall be installed on each chilled and cooling water lines at higher points than each water header.
 - Drain valves shall be installed at the lowest position between the stop valves of chilled and cooling water and the Machine and the drain valve shall be piped to the drain ditch.
- 9) There shall be a sufficient clearance for access to the absorber, evaporator, condenser, and generator to facilitate inspection and cleaning work.



Exclusively Distributed by

LENERGY MAGYARORSZÁG KFT.

H-1034 Budapest, Kiscelli út 7-9.

mobil: +36703758894

e-mail: zvarga@lenergy.hu

All contents subject to change without prior notice